

For units with serial numbers up to # 7597-5

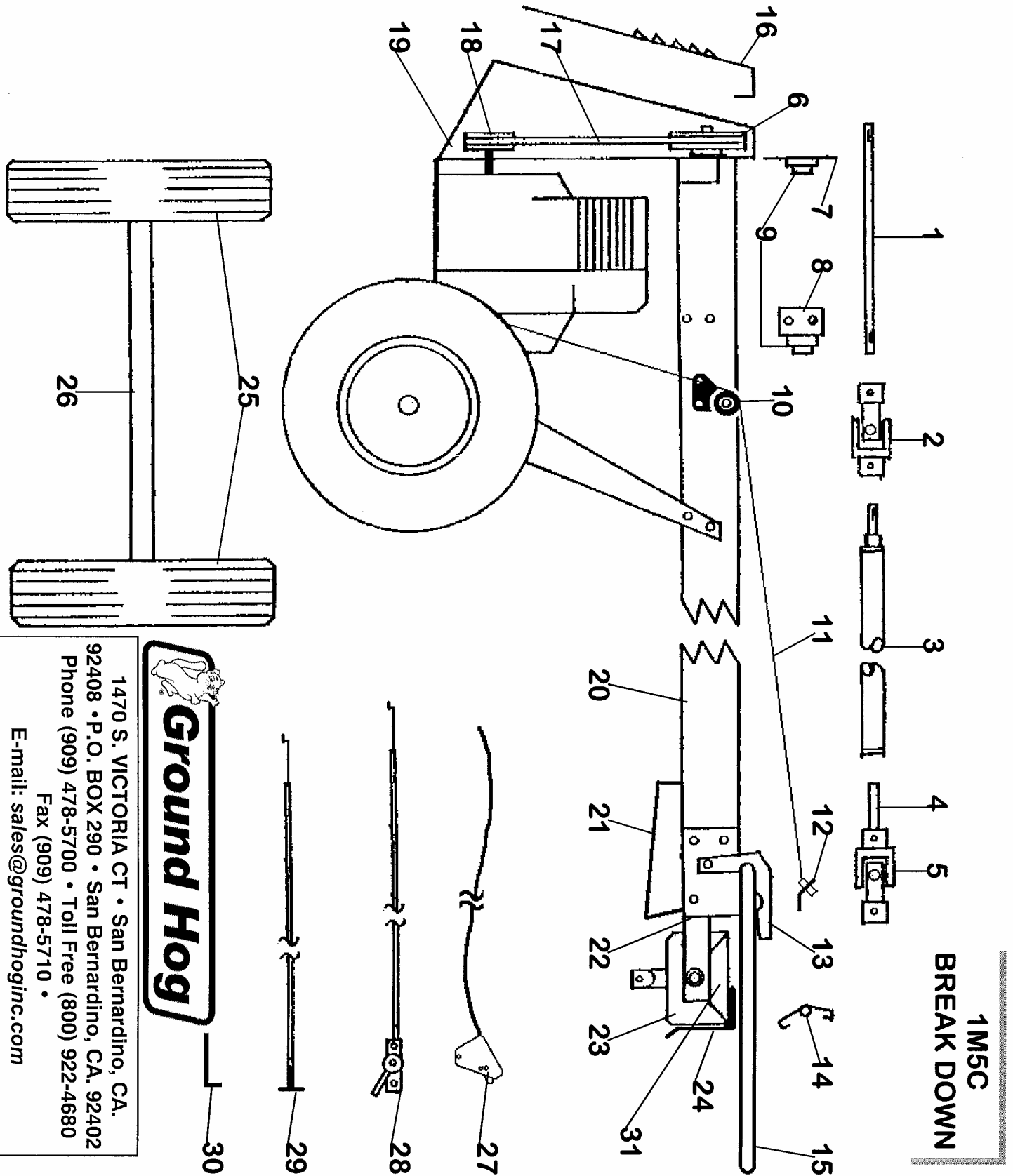

1M5C
BREAK DOWN



1470 S. VICTORIA CT • San Bernardino, CA.
 92408 • P.O. BOX 290 • San Bernardino, CA. 92402
 Phone (909) 478-5700 • Toll Free (800) 922-4680
 Fax (909) 478-5710 •
 E-mail: sales@groundhoginc.com

1M5C PARTS LIST

REF #	PART #	DESCRIPTION
1	500	JACK SHAFT (REQUIRES 2 NO. 13 KEYS)
2	515	U - JOINT ROUND / ROUND
3	505	DRIVE SHAFT (COMES WITH SPACER & NO. 13 KEY)
4	510	SQUARE SLIDING MEMBER
5	520	U - JOINT SQUARE / ROUND
6	BK60	PULLEY
7	580	BEARING PLATE
8	530	JACK SHAFT REAR SUPPORT
9	525	FLANGE BEARING
10	507	STARTER ROPE PULLEY
	508	PULLEY BRACKET
	509	STARTER ROPE GUIDE
11	503	STARTER ROPE (SPECIFY ENGINE)
12	504	ROPE GUIDE ASSEMBLY
13	540	HANDLE BAR LATCH
14	545	HANDLE BAR LATCH SPRING
15	550	HANDLE BAR
16	566	BELT COVER
17	B37	BELT
18	GW12-30	CENTRIFUGAL CLUTCH (COMES WITH 3/16 SQUARE KEY)
19	586	ENGINE FRAME
20	535	BOOM
21	501	U - JOINT GUARD
22	560	PIVOT BRACKET SET
	560-1	LEFT PIVOT BRACKET
	560-2	RIGHT PIVOT BRACKET
	561	PIVOT BRACKET BUSHING
23	GHU-1M	GEAR BOX
24	556	HANDLE BAR STOP
25	MWA	1M TIRE & WHEEL ASSEMBLY
26	595	AXLE
27	SS1	IGNITION SWITCH ASSEMBLY (SEE GEARBOX SHEET FOR ADDIONAL PARTS)
28	MTA	THROTTLE ASSEMBLY
29	502	CHOKER CONTROL
30	512	CHOKER BRACKET
31	555	PIVOT PLATE

For units with serial numbers beginning at # 7598-5

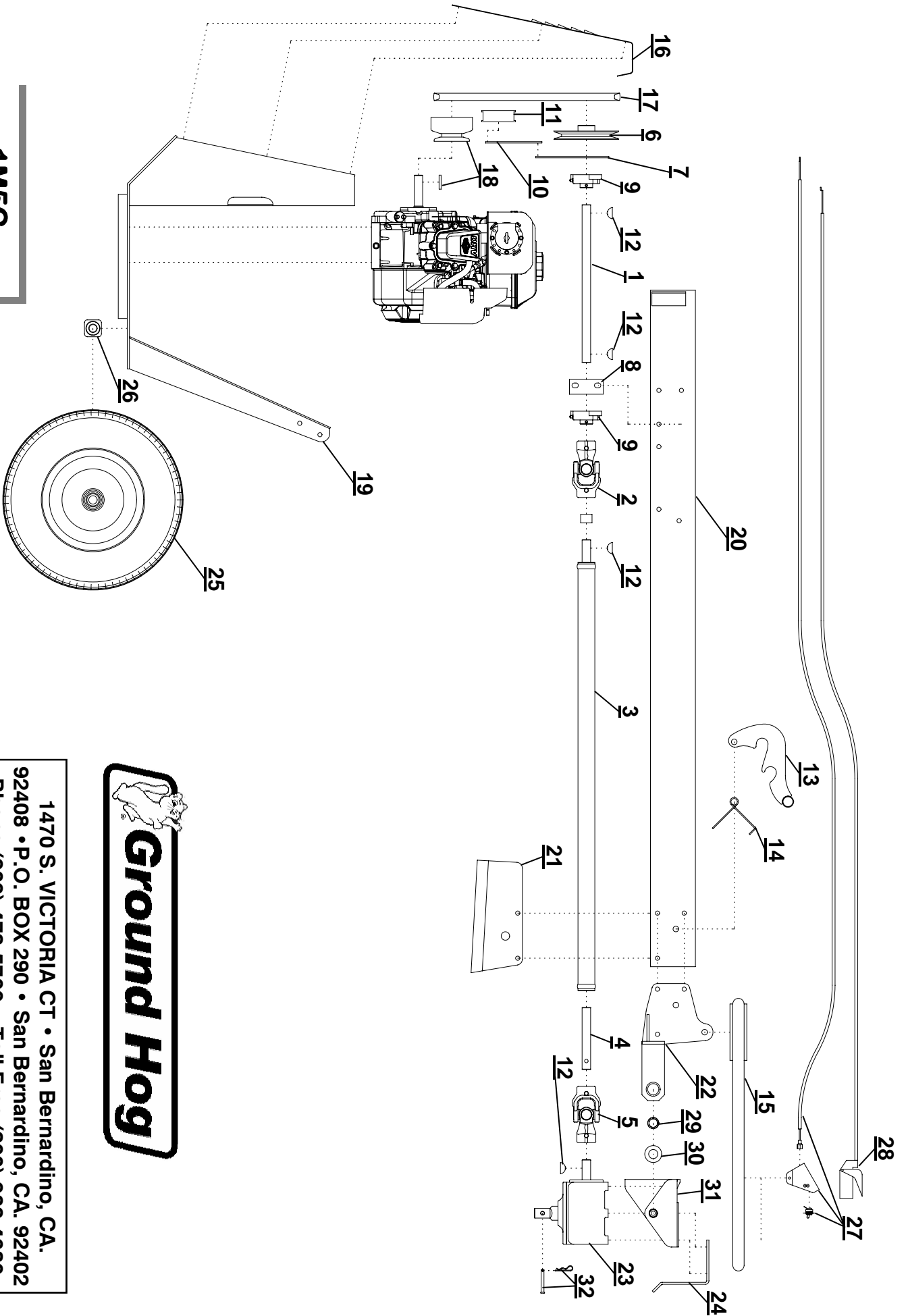

**1M5C
BREAK DOWN**



1470 S. VICTORIA CT • San Bernardino, CA.
 92408 • P.O. BOX 290 • San Bernardino, CA. 92402
 Phone (909) 478-5700 • Toll Free (800) 922-4680
 Fax (909) 478-5710 •
 E-mail: sales@groundhoginc.com

1M5C PARTS LIST

REF #	PART #	DESCRIPTION
1	500	JACK SHAFT (REQUIRES 2 NO. 13 KEYS)
2	515	U - JOINT ROUND / ROUND
3	505	DRIVE SHAFT (COMES WITH SPACER & NO. 13 KEY)
4	510	SQUARE SLIDING MEMBER
5	520	U - JOINT SQUARE / ROUND
6	BK60	PULLEY
7	580	BEARING PLATE
8	530	JACK SHAFT REAR SUPPORT
9	525	FLANGE BEARING
10	582	IDLER ARM
11	584	IDLER
12	NO. 13	3/16" WOODRUFF KEY
13	540	HANDLE BAR LATCH
14	545	HANDLE BAR LATCH SPRING
15	550	HANDLE BAR
16	566	BELT COVER
17	B37	BELT
18	GW12-30	CENTRIFUGAL CLUTCH (COMES WITH 3/16 SQUARE KEY)
19	586	ENGINE FRAME
20	535	BOOM
21	501	U - JOINT GUARD
22	560	PIVOT BRACKET SET
	560-1	LEFT PIVOT BRACKET
	560-2	RIGHT PIVOT BRACKET
23	GHU-1M	GEAR BOX
24	556	HANDLE BAR STOP
25	MWA	1M TIRE & WHEEL ASSEMBLY
26	595	AXLE
27	SS1	IGNITION SWITCH ASSEMBLY (SEE GEARBOX SHEET FOR ADDIONAL PARTS)
28	MTA-1	SPRING RETURN THROTTLE ASSEMBLY
29	561	PIVOT BUSHING
30	1700	3/4" WASHER
31	555	PIVOT PLATE
32	1300	AUGER ATTACHMENT PIN



GEAR BOX BREAK DOWN

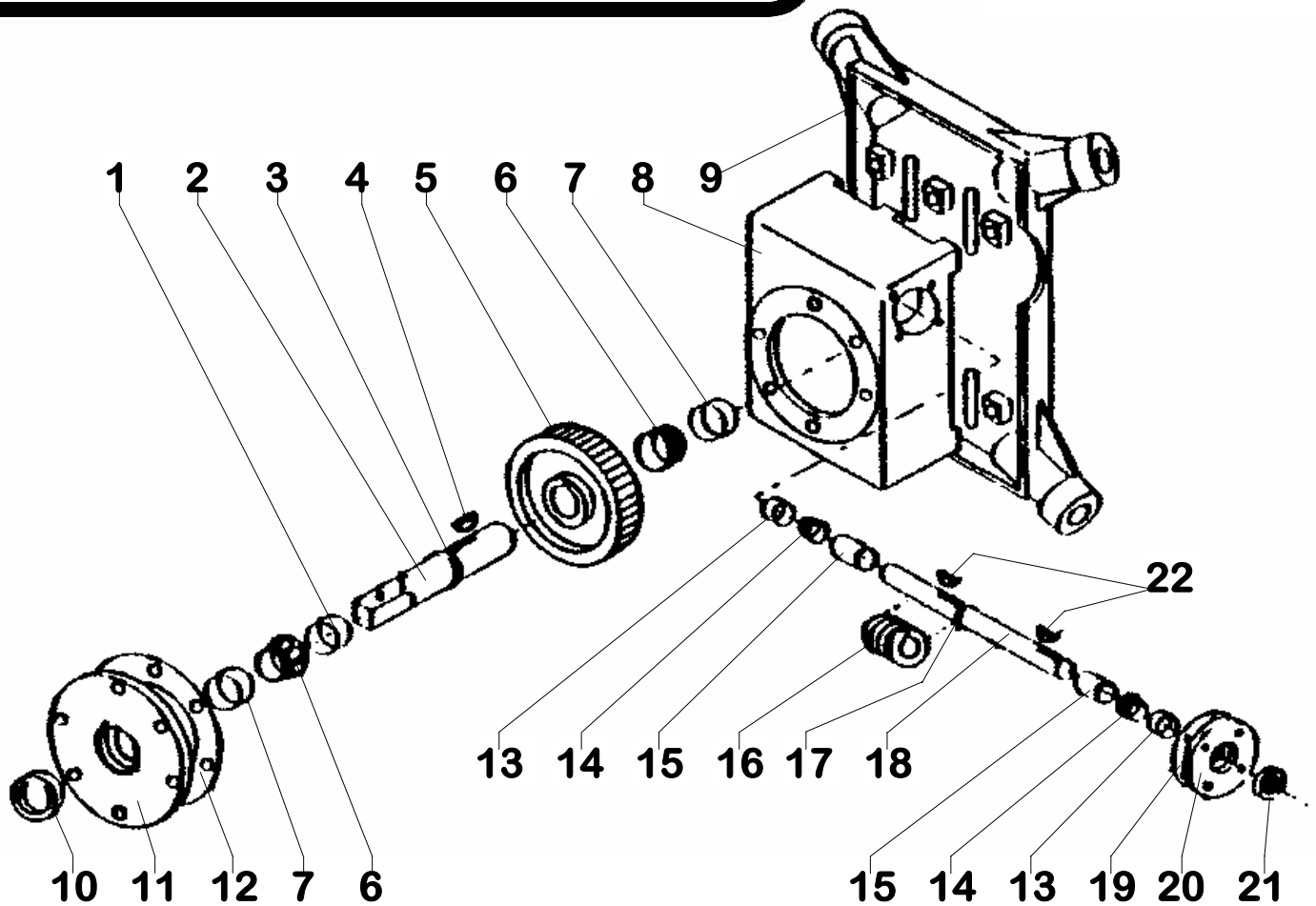

PLEASE SPECIFY IF YOU ORDERING PARTS FOR A ONE-MAN OR A TWO-MAN EARTHDRILL

1.	O.P.S.	Output shaft spacer	12.	GHU-2GS	Output gasket set
2.	GHU-5	Output shaft	13.	LM11910	Input cup
3.	RS-125	Output spiral ring	14.	LM11949	Input bearing
4.	NO. 21	1/4 woodruff key	15.	I.P.S.	Input spacer
5.	G71-3X	Bronze gear	16.	H1618	Worm gear
6.	08125	Output bearing	17.	RS-715	Input spiral ring
7.	08231	Output cup	18.	GHU-6	Input shaft
8.	GHU-1	Gear case			Specify machine
9.	GHU-4	Engine base	19.	GHU-3GS	Input gasket set
10.	12341	Output seal	20.	GHU-3	Input cap
11.	GHU-2	Output cap	21.	7485	Input seal
			22.	3/16 Key	Specify square or Woodruff

GHU 10:1 = Complete C-71-5 & D5 gear box

GHU-1M = Complete 1M & 1M5C gear box

1470 S. VICTORIA CT • San Bernardino, CA. 92408 • P.O. BOX 290 • San Bernardino, CA. 92402

Phone (909) 478-5700 • Toll Free (800) 922-4680

Fax (909)478-5710 • E-mail: sales@groundhoginc.com



C-71-5, D-5 & SWITCH PARTS

GW12-30	Centrifugal clutch (C-71-5)	BG	Belt guard
AX26	Two-man drive belt	272	Belt guard bracket
AK59	Pulley	SS2A	Remote stop switch assembly
600	Handle bar	SS3	ignition pig tail
TA-1	Spring return throttle (C-71-5)	SS4	Loom clamp
	Kits available. specify engine	SS5	Switch cover
TA	Throttle assembly (D-5)	SS6	Ignition switch with mount
600T	Throttle handle bar (D-5)	SS8	Ignition wire
610	Handle bar grip	SS2	Toggle switch
BGA	Complete belt guard assembly		

GEAR BOX CARE

The GHU gear box, used on the Ground Hog earth drills is a right angle, worm drive transmission. It features tapered roller bearings at all bearing points, ground and polished, high strength input and output shafts, and a hardened worm gear against a bronze drive gear.

Due to its simplicity and high quality components, this type of transmission has proven itself to be extremely reliable and durable on our earth drills for over 40 years. It is not unusual for this transmission to be in service for 20 years without major repairs.

If internal repairs are needed, pay close attention to the number of gaskets that are used on the covers. These are "shim" type gaskets that are color coded to identify thickness. When replacing internal parts, always start with the same number and thickness of gaskets, adding or removing gaskets until the shaft turns freely with no noticeable endplay. Use a soft type of gasket sealer on the inside flange of the cover during final assembly. Use 1 quart approx of a #140 gear lube.